

**STRAIGHT BNC MALE-FME MALE ADAPTER**

**R141.042.000**

Series : BNC

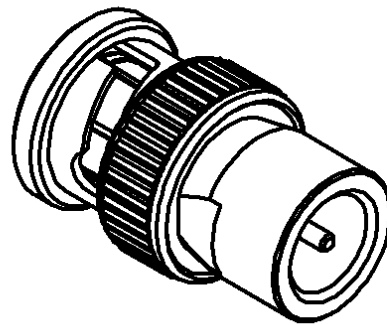
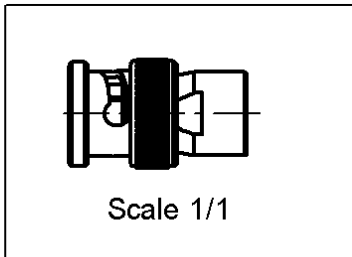
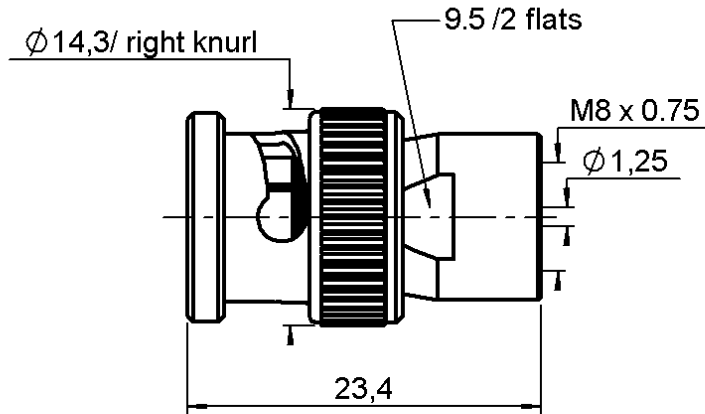

All dimensions are in mm.



COMPONENTS	MATERIALS	PLATINGS ( $\mu\text{m}$ )
BODY	BRASS	NICKEL 2
CENTER CONTACT	BRASS	GOLD 0.2 OVER NICKEL 2
OUTER CONTACT	-	-
INSULATOR	WHITE POLYPROPYLENE	-
GASKET	SILICONE RUBBER	-
OTHERS PARTS	ZAMAK	NICKEL 2
-	-	-
-	-	-

Issue : 0206 E

In the effort to improve our products, we reserve the right to make changes judged to be necessary.



**STRAIGHT BNC MALE-FME MALE ADAPTER**

**R141.042.000**

Series : **BNC**

**PACKAGING**

**SPECIFICATION**

Standard	Unit	Other
<b>100</b>	<b>'W' option</b>	<b>Contact us</b>

**ELECTRICAL CHARACTERISTICS**

**ENVIRONMENTAL**

Impedance		<b>50</b> Ω
Frequency		<b>0-1</b> GHz
VSWR	<b>NA</b> +	<b>0.000</b> x F(GHz) Maxi
Insertion loss		<b>NA</b> √F(GHz) dB Maxi
RF leakage	- (	<b>NA</b> - F(GHz)) dB Maxi
Voltage rating		<b>500</b> Veff Maxi
Dielectric withstanding voltage		<b>1500</b> Veff mini
Insulation resistance		<b>5000</b> MΩ mini

Operating temperature	<b>-55/+100</b> ° C
Hermetic seal	<b>NA</b> Atm.cm3/s
Panel leakage	<b>NA</b>

**OTHERS CHARACTERISTICS**

Assembly instruction **NA**

Others :  
-

**MECHANICAL CHARACTERISTICS**

Center contact retention		
Axial force – Mating end	<b>27</b>	N mini
Axial force – Opposite end	<b>27</b>	N mini
Torque	<b>NA</b>	N.cm mini
Recommended torque		
Mating	<b>NA</b>	N.cm
Panel nut	<b>NA</b>	N.cm
Mating life	<b>500</b>	Cycles mini
Weight	<b>10.300</b>	g

Issue : 0206 E

In the effort to improve our products, we reserve the right to make changes judged to be necessary.

